

ISOMAG

The friendly magmeter

DATA SHEET

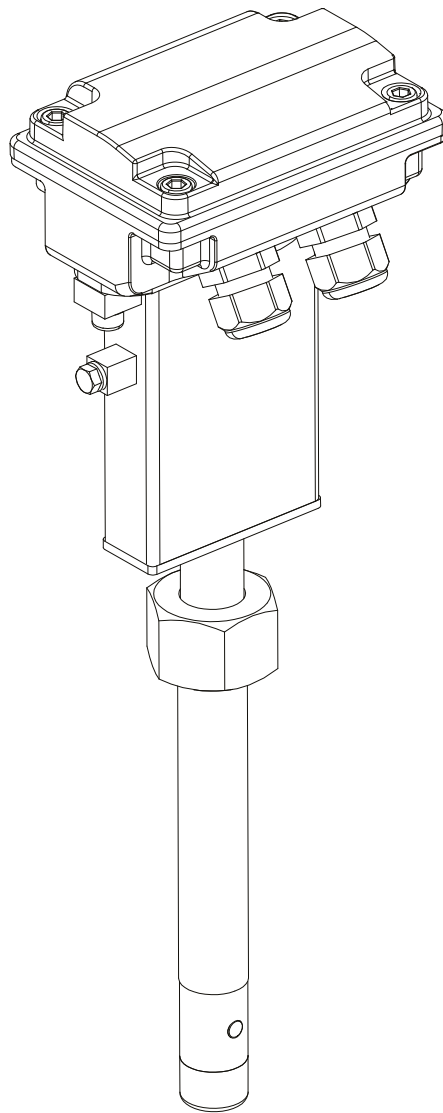

MS 3780

CE

ISOIL 
INDUSTRIA



INDEX

OVERALL FEATURES	2
STANDARD FEATURES	2
OPTIONAL FEATURES	2
TECHNICAL DATA	2
OVERALL DIMENSIONS	3
LAYOUT	4
INSTALLATION	5
INSTALLATION RECOMMENDATIONS	6
SENSOR GROUNDING	7
SENSOR VERSIONS / JUNCTIONS BOX	8
SEPARATE VERSION	9
ACCURACY TABLE	10
HOW TO ORDER	11



The manufacturer guarantees only English text available on our web site www.isoli.com

TECHNICAL DATA

OVERALL FEATURES

Size for pipe line Ø	<input type="checkbox"/> Size 1 Ø ≤ 500mm <input type="checkbox"/> Size 2 Ø ≤ 1000mm <input type="checkbox"/> Size 3 Ø ≤ 2000mm
Minimum conductivity	<input type="checkbox"/> 5 µS/cm
Humidity Range	<input type="checkbox"/> 0÷100% (IP 67)
Accuracy	<input type="checkbox"/> See relevant converter data sheet
CE Certification	<input type="checkbox"/> Yes

STANDARD FEATURES

Body material	<input type="checkbox"/> Stainless steel AISI316
Nominal pressure	<input type="checkbox"/> 1600 kPa
Process connection	<input type="checkbox"/> 1" Threaded end
Version – protection rating	<input type="checkbox"/> Compact IP67
Lining material/gasket	<input type="checkbox"/> PEEK/FPM
Liquid temperature	<input type="checkbox"/> -20°C ÷ 100°C compact version <input type="checkbox"/> -20°C ÷ 130°C separate version
Electrodes material	<input type="checkbox"/> Hastelloy C276

OPTIONAL FEATURES

(CHECK FOR MORE DETAILS 'HOW TO ORDER' ON LAST PAGE)

Size for pipe line Ø	<input type="checkbox"/> Other on request
Nominal pressure	<input type="checkbox"/> Others on request
Process connection	<input type="checkbox"/> Others on request
Electrodes material	<input type="checkbox"/> Others on request
Version – protection rating	<input type="checkbox"/> Separate version (max 20m) – IP 68 <input type="checkbox"/> Separate version (max 500 m), with preamplifier – IP 67 (OPT. IP 68)

OVERALL DIMENSIONS

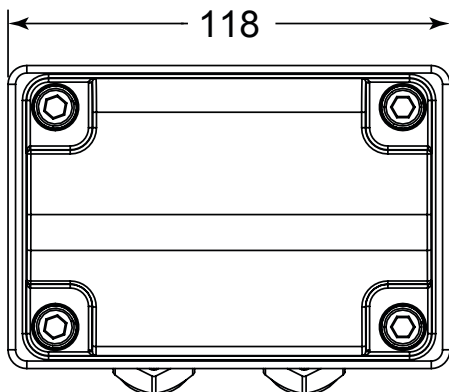
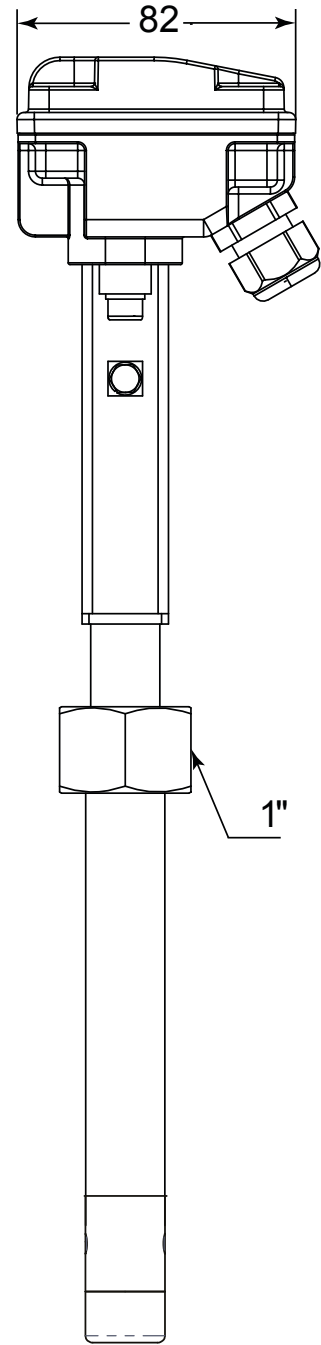
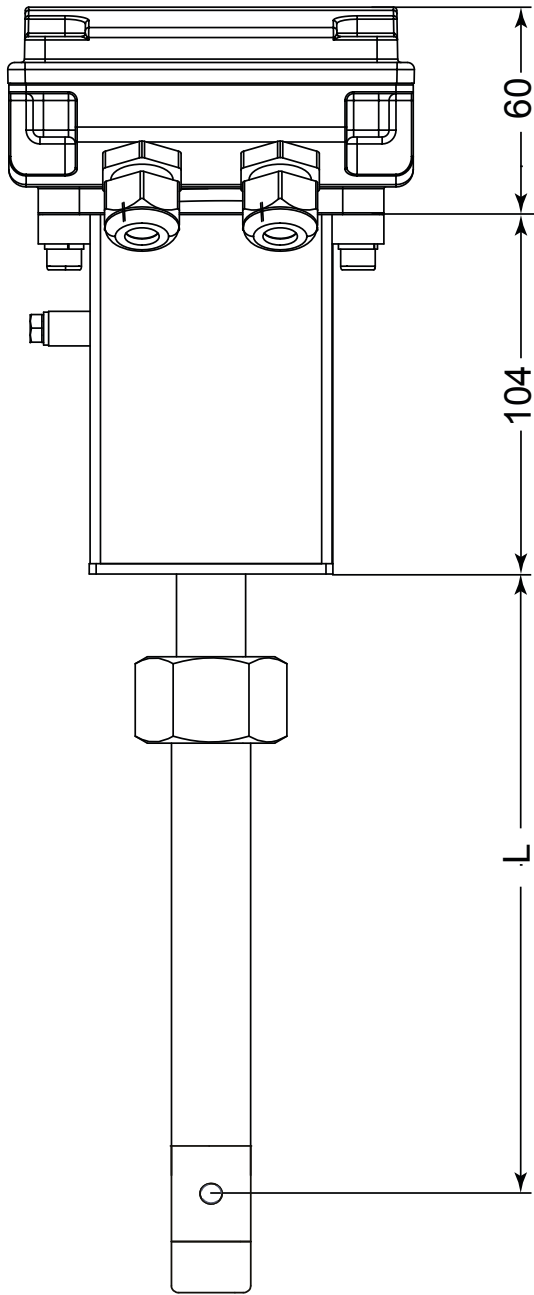

The manufacturer guarantees only English text available on our web site www.isoli.com

LAYOUT

POS.	DESCRIPTION
1	SCREW M6x16
2	GROWER Ø6
3	JUNCTION BOX COVER
4	O-RING 4400
5	SCREW M4x6
6	PCB FOR SEPARATE VERSION (NORMAL OR PREAMPLIFIER)
7	JUNCTION BOX MAIN HOUSING
8	CABLEGLANDE PG9
9	O-RING 155
10	SCREW M5x10
11	GROWER Ø5
12	SENSOR MS3770
13	GASKET PTFE

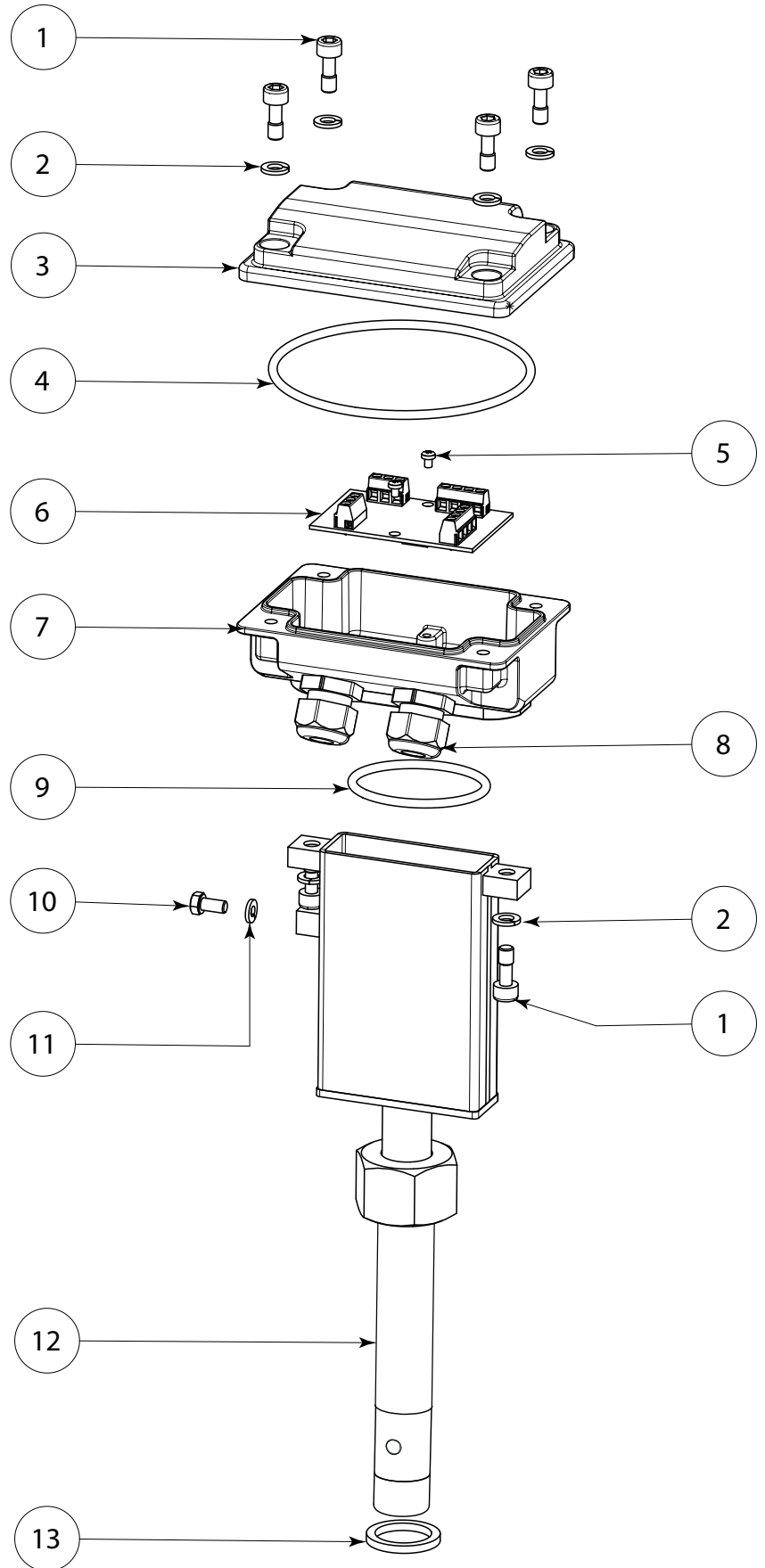

The manufacturer guarantees only English text available on our web site www.isoil.com

INSTALLATION

- Cut the Ø 1" jacket as in picture 1 (dimensions in pic. 6)
- **ATTENTION:** consider the necessary over-metal for the welding operation (pic. 2)

Z=L-S-1/8D-32

Pic. 1

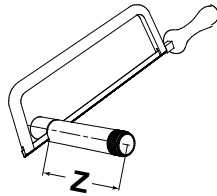

- weld the jacket to the pipe line

Recommended operative dimensions for 1" screw

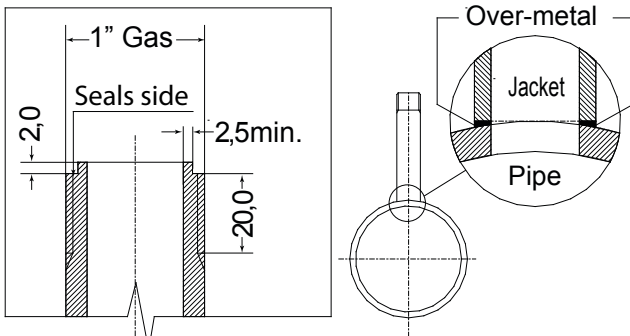

Pic. 2

- Align longitudinally the connector box with the pipe line axis (pic. 5)
- Tighten the nut with a spanner keeping the alignment (pic. 4). The fixing of the nut must guarantee the sealing of the gasket

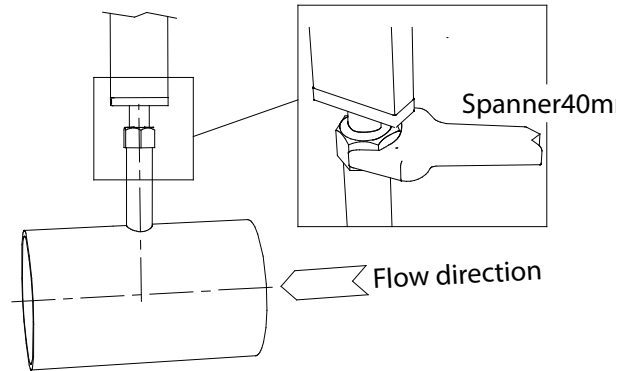

Pic. 4

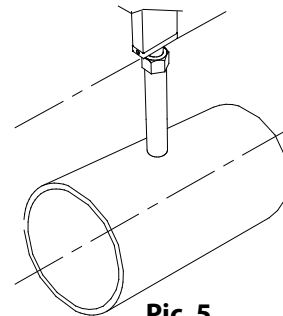

Pic. 5

- Place gasket into the sensor
- Insert the sensor into the Ø 1" nipple

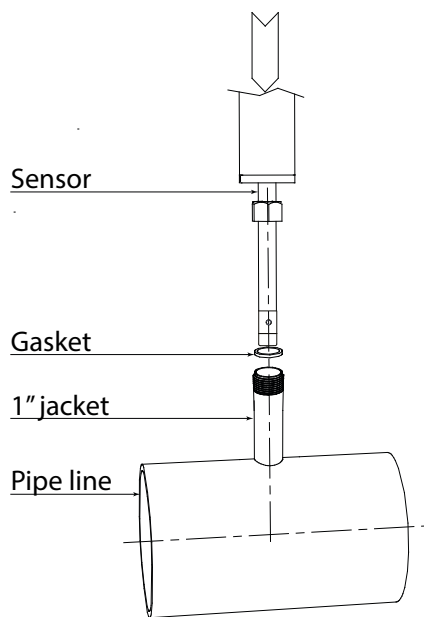

Pic. 3

SIZE	DN RANGE	L
SIZE 1	DN 80 up to DN 500	176
SIZE 2	DN 80 up to DN 1000	244
SIZE 3	DN 80 up to DN 2000	462

Sensor installed

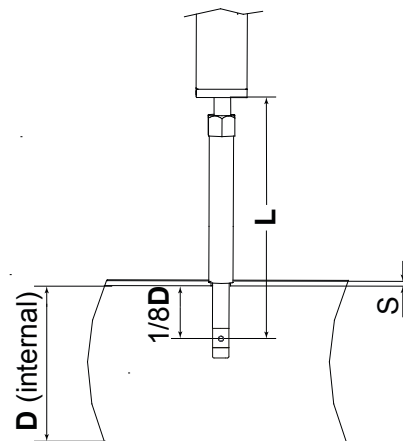

Pic. 6

INSTALLATION RECOMMENDATIONS

In vertical installations an ascending flow is preferable. For vertical installations with descending flow direction contact the manufacturer

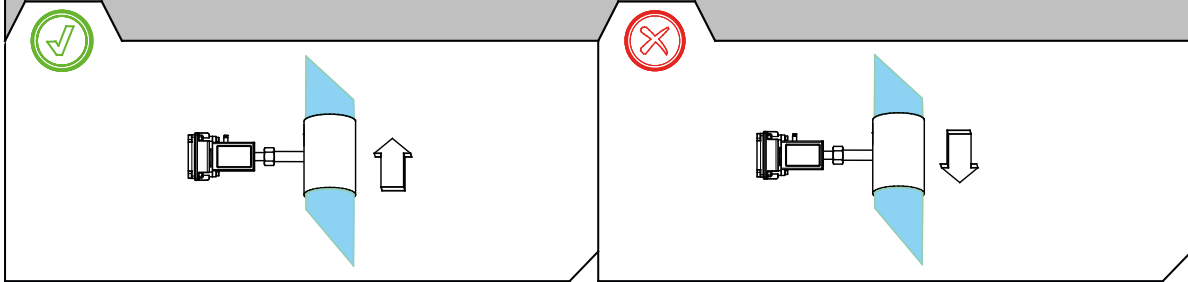

Avoid a partially empty pipe, during operation the pipe must be either completely full of liquid or completely empty

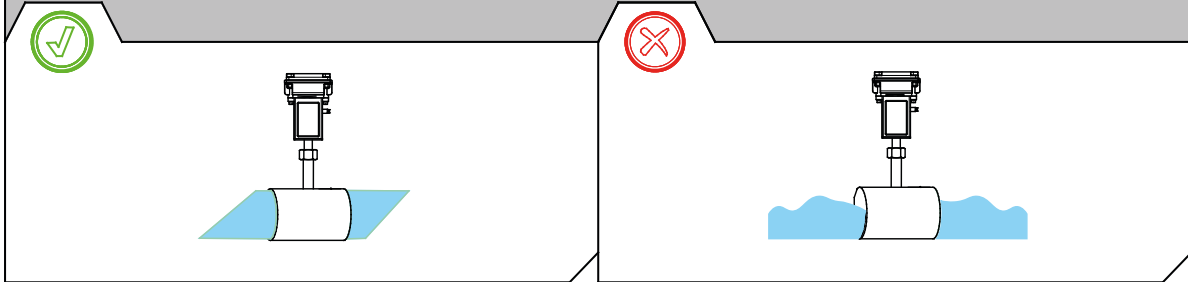

Install the sensor away from bends and hydraulic accessories

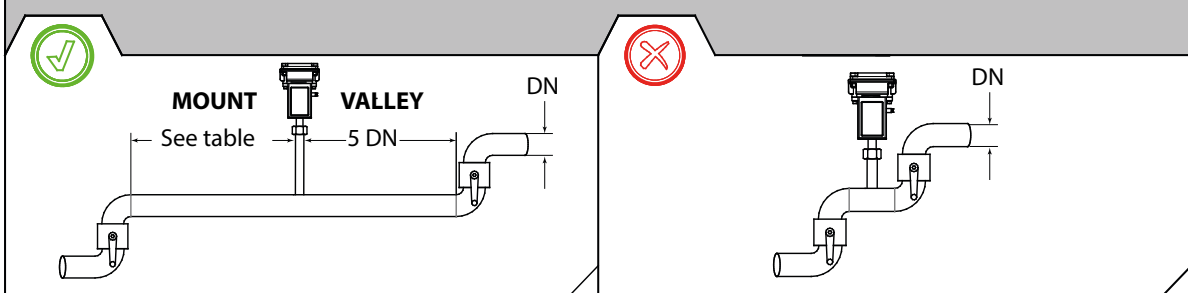

Install the sensor away from bends and hydraulic accessories

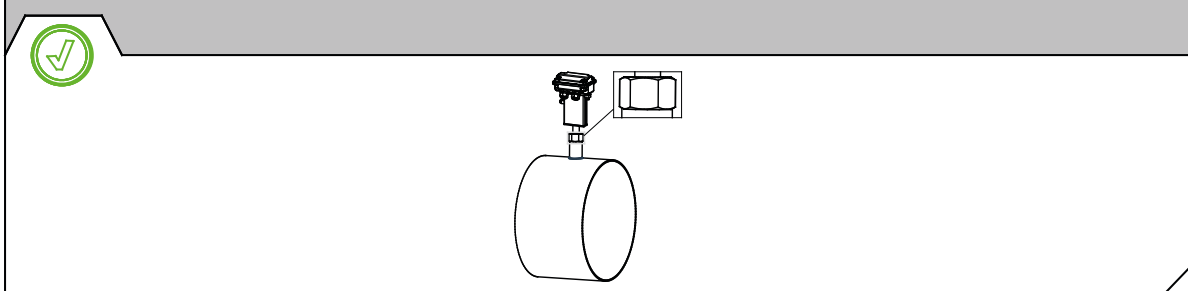

Min upstream straight length expressed in multiples of pipe diameter. Table according data from UNI10727_1998

Disturbance upstream from the measuring point	Valid for a measurement at the point of mean axial velocity	Valid for a measurement on the axis of the pipe
90° elbow or a t-bend	50	25
Several 90° coplanar bends	50	25
Several 90° non- coplanar bends	80	50
Total angle convergent 18 to 36°	30	10
Total angle divergent 14 to 28°	55	25
Fully opened butterfly valve	45	25
Fully opened plug valve	30	15

SENSOR GROUNDING

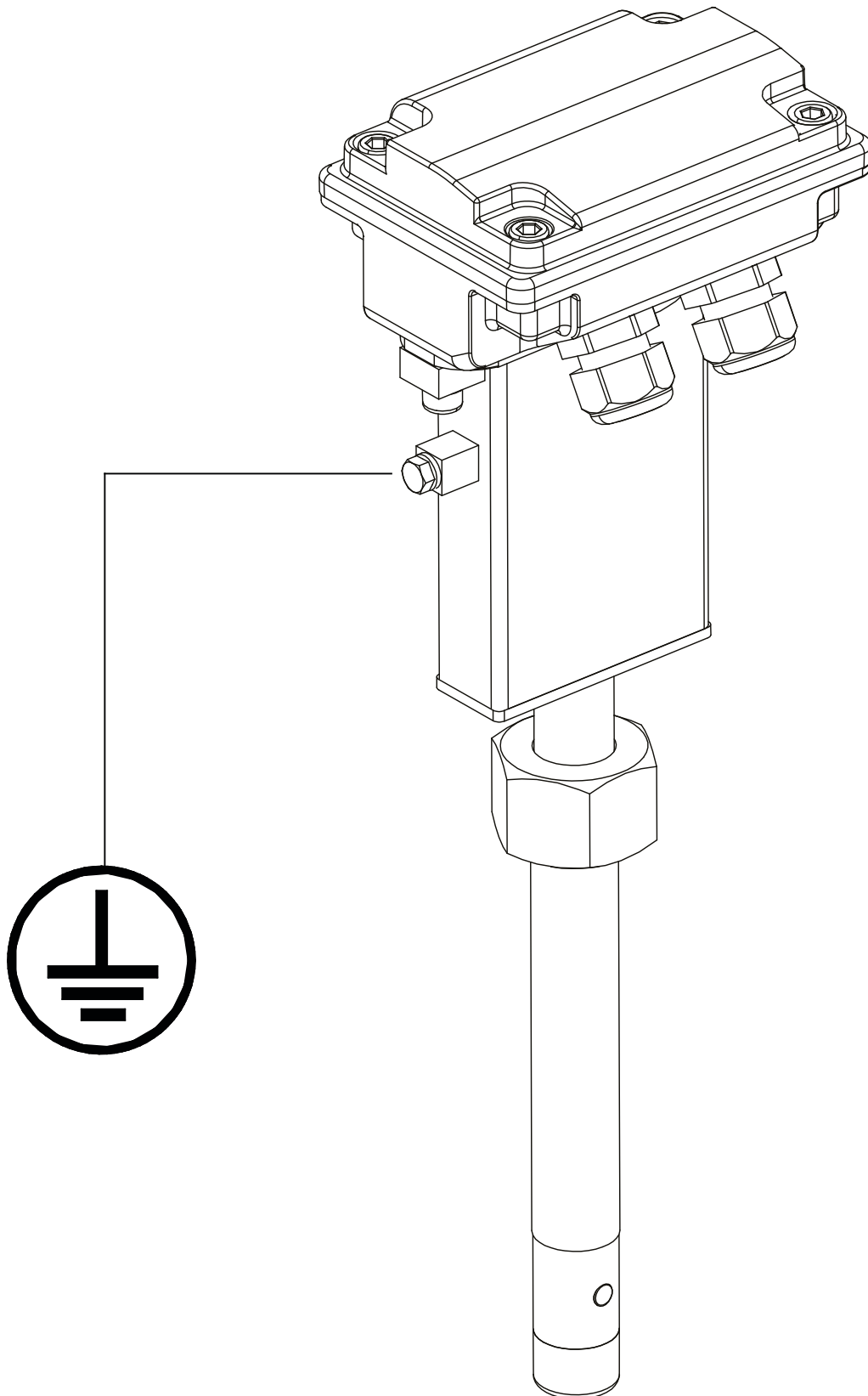

For the correct operation of the meter the sensor and liquid must be equipotential. **ALWAYS** connect sensor and converter to the ground.

For grounding with a cathodic protection pipe, please contact the manufacturer.

SENSOR VERSIONS / JUNCTIONS BOX

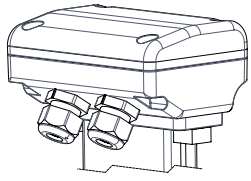
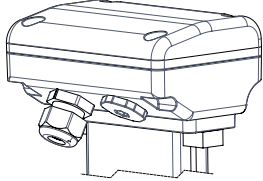
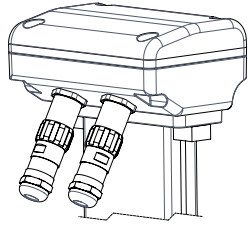
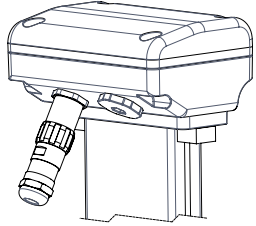
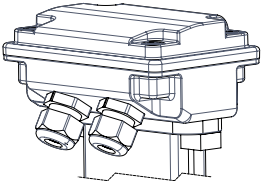
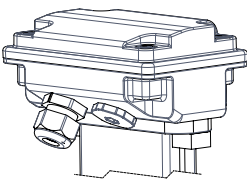
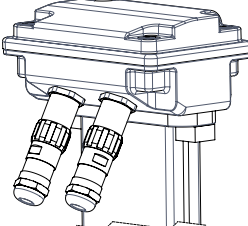
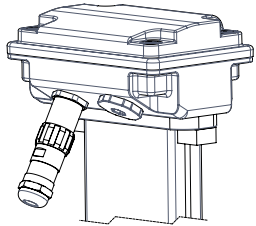
	1	2	3	4
A PAINTED ALUMINIUM				
B AISI 304				

The manufacturer guarantees only English text available on our web site www.isoil.com

PRICE LIST OPTIONS	JUNCTION BOX TYPE (surface finish)
A	Without junction box, converter connected on the connections box
B	A-1 A-2 only for ML110
G	A-4
F	A-3
N	A-2 with preamplifier
Q	A-4 with preamplifier
U	B-1 (raw) B-2 only for ML110 (raw)
S	B-4 (raw)
T	B-3 (raw)
P	B-2 with preamplifier (raw)
R	B-4 with preamplifier (raw)
K	B-1 (polished) B-2 only for ML110 (polished)
Y	B-4 (polished)
W	B-3 (polished)
V	B-2 with preamplifier (polished)
J	B-4 con preamplificatore (finitura lucidata)

SEPARATE VERSION

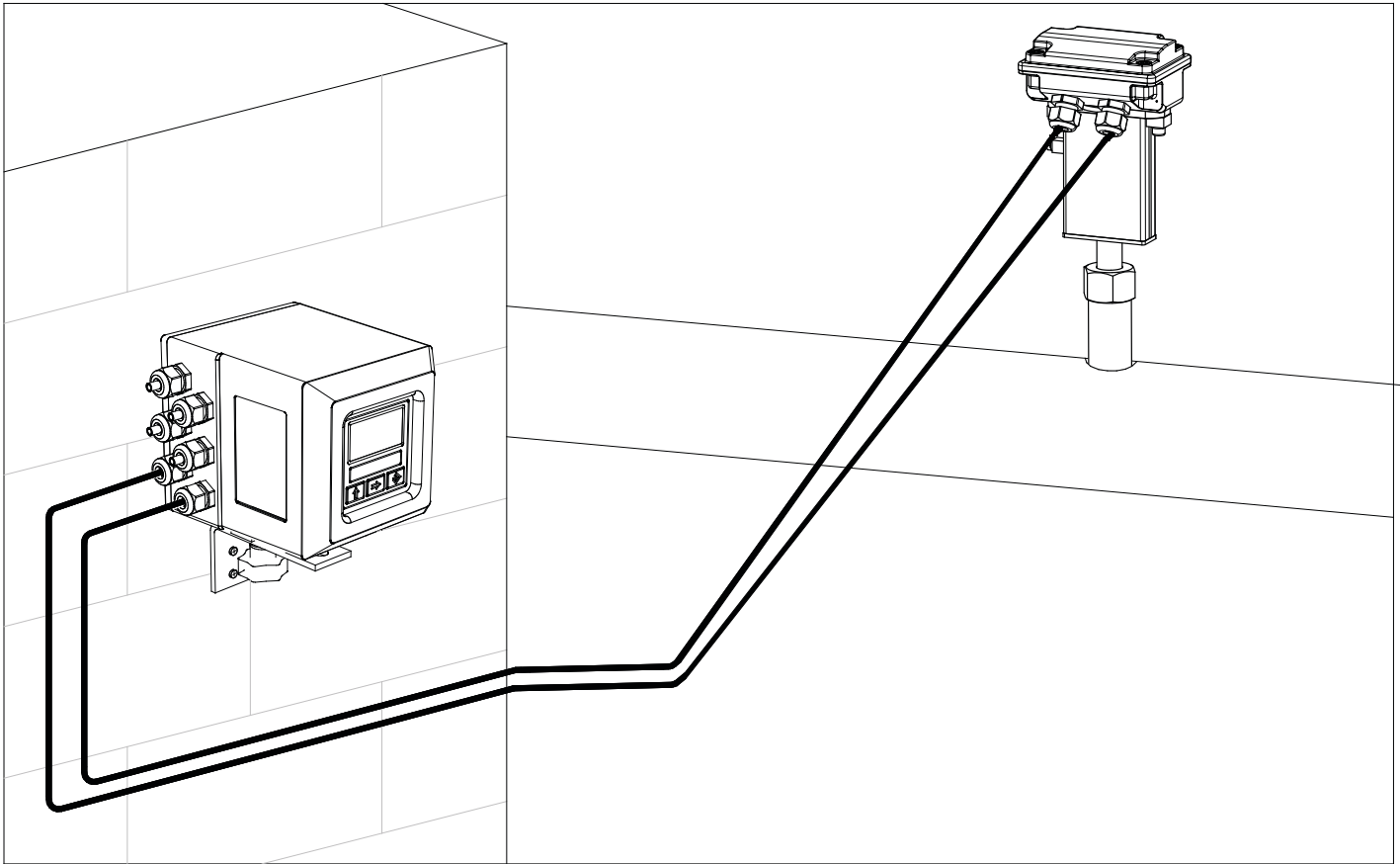

The manufacturer guarantees only English text available on our web site www.isoli.com

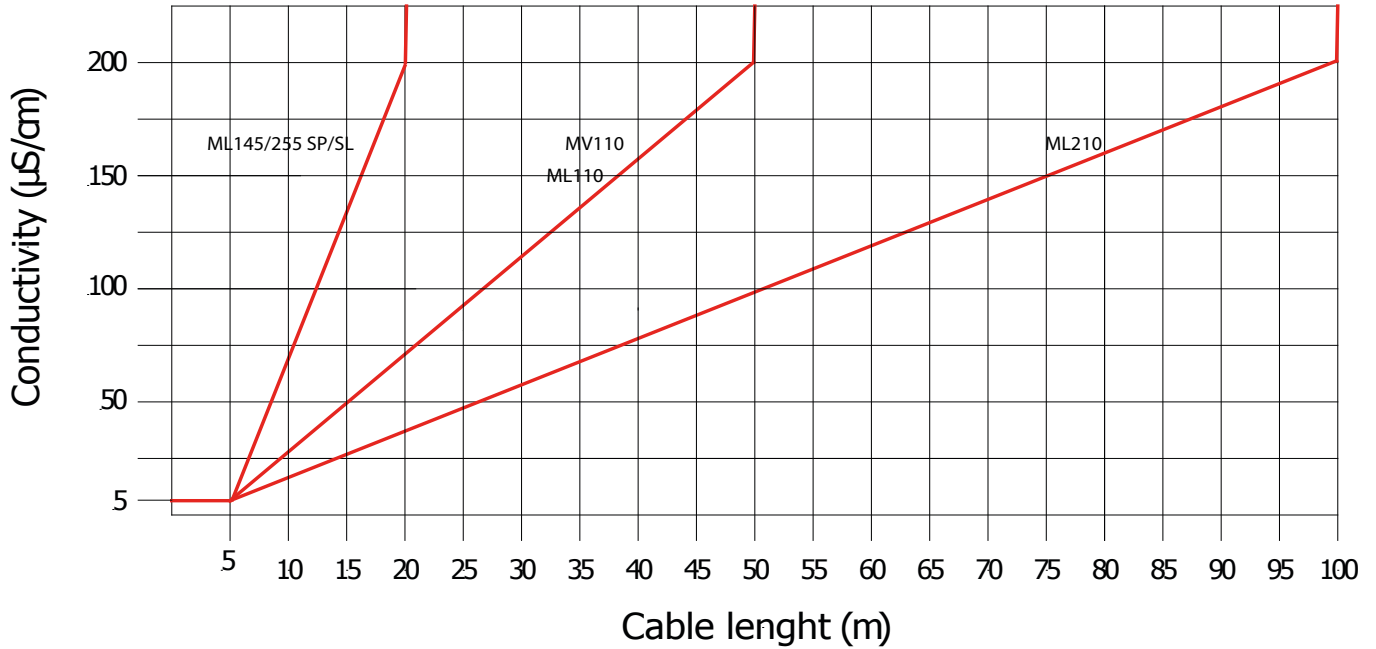

Note:

- It is recommended to install the connection cables away from, or protect against sources of electromagnetic noise.
- The minimum conductivity of the liquid medium to ensure correct functionality of the empty pipe detection is 20 µS/cm

ACCURACY TABLE

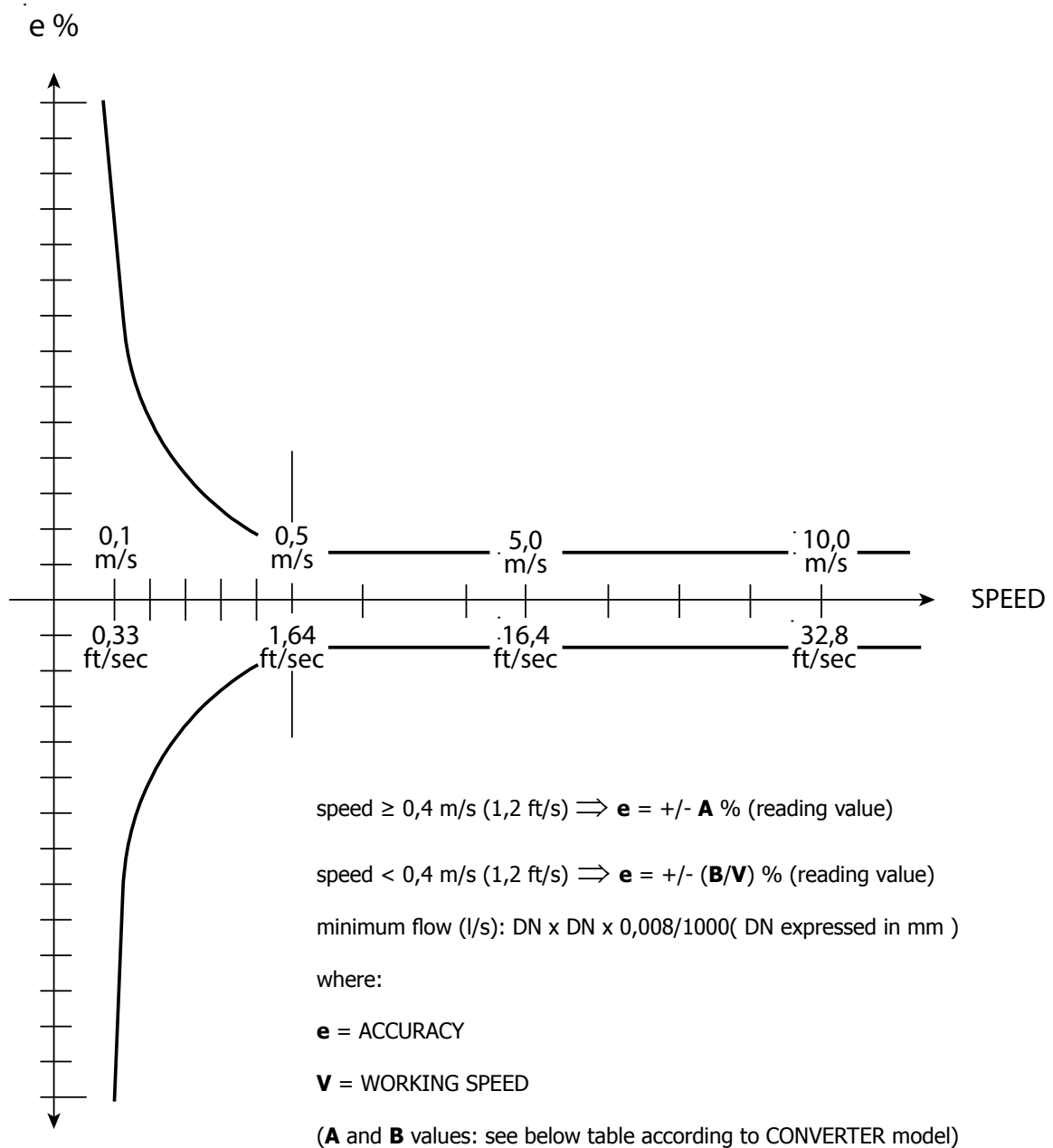

A	B (Speed m/s)	B (Speed ft/s)
2	0,8	0,24

Reference conditions:

- Constant flow rate during the test
- Pressure: >30 kPa
- Flow condition : fully developed flow profile
- Zero stability +/- 0,005 %
- ID accuracy: mean value better than 1%, IDmin/IDmax>0,98

The manufacturer guarantees only English text available on our web site www.isoil.com

HOW TO ORDER

MS 3780		
code 1	Suitable for piping diameter	
	1	Suitable for diameter < / = 500 mm.
	2	Suitable for diameter < / = 1000 mm.
	3	Suitable for diameter < / = 2000 mm.
	9	Suitable for diameter: to be specified
Sensor and electrodes material / lining		
A	A	Sensor material AISI316, Peek lining, electrodes in Hastelloy C276 , gasket in FKM , NEK in SS AISI 304
	Z	Sensor material: to be specified
Connection type		
1	1	1" female threaded connection
	0	Connection: to be specified
Number and electrodes material		
A	A	Compact version , IP67 protection rate
	B	Separate version, Painted Aluminum JB, protection rate IP68, standing immersion with 1,5 m of head water - (DEFINE THE CABLE LENGTH - ADD THE COST)
	G	Separate version, Painted Aluminum JB, N° 1 connectors IP 68 suitable for fast cable connections - (DEFINE THE CABLE LENGTH - ADD THE COST)
	F	Separate version, Painted Aluminum JB, N° 2 connectors IP 68 suitable for fast cable connections - (DEFINE THE CABLE LENGTH - ADD THE COST)
	N	Separate version, Painted Aluminum JB , PREAMPLIFIER*, protection rate IP67 - (DEFINE THE CABLE LENGTH MAX 500 m-ADD THE COST)
	Q	Separate version, Painted Aluminum JB, PREAMPLIFIER*, N° 1 connectors IP 68 suitable for fast cable connection - (DEFINE THE CABLE LENGTH MAX 500 m-ADD THE COST)
	U	Separate version, AISI 304 JB RAW, protection rate IP68, standing immersion with 1,5 m of head water - (DEFINE THE CABLE LENGTH - ADD THE COST)
	S	Separate version, AISI 304 JB RAW, with N° 1 connectors IP 68 suitable for fast cable connections - (DEFINE THE CABLE LENGTH - ADD THE COST)
	T	Separate version, AISI 304 JB RAW, N° 2 connectors IP 68 suitable for fast cable connections - (DEFINE THE CABLE LENGTH - ADD THE COST)
	P	Separate version, AISI 304 JB RAW, PREAMPLIFIER*, protection rate IP67 - (DEFINE THE CABLE LENGTH MAX 500 m-ADD THE COST)
	R	Separate version, AISI 304 JB RAW, PREAMPLIFIER* N° 1 connectors IP 68 suitable for fast cable connections to - (DEFINE THE CABLE LENGTH MAX 500 m-ADD THE COST)
	K	Separate version, AISI 304 JB POLISHED, protection rate IP68, standing immersion with 1,5 m of head water - (DEFINE THE CABLE LENGTH - ADD THE COST)
	Y	Separate version, AISI 304 JB POLISHED, with N° 1 connectors IP 68 suitable for fast cable connections - (DEFINE THE CABLE LENGTH - ADD THE COST)
	W	Separate version, AISI 304 JB POLISHED, N° 2 connectors IP 68 suitable for fast cable connections - (DEFINE THE CABLE LENGTH - ADD THE COST)
V	Separate version, AISI 304 JB POLISHED, PREAMPLIFIER*, protection rate IP67 - (DEFINE THE CABLE LENGTH MAX 500 m-ADD THE COST)	
J	Separate version, AISI 304 JB POLISHED, PREAMPLIFIER* N° 1 connectors IP 68 suitable for fast cable connections to - (DEFINE THE CABLE LENGTH MAX 500 m-ADD THE COST)	

MS3780-1A1A (Example of Complete code for order)

ISOIL INDUSTRIA S.p.A.

HEAD OFFICE	SERVICE
Via Fratelli Gracchi, 27 20092 Cinisello Balsamo (MI) Tel +39 02 66027.1 Fax +39 02 6123202 vendite@isoil.it	isomagservice@isoil.it

If you want to find the complete list of our distributors access at the following link:
http://www.isoil.com/u_vendita.asp



Due to the constant technical development and improvement of its products, the manufacturer reserves the right to make changes and/or modify the information contained in this document without notice.